

# ELF Reception

## Signal hunting below 150 kHz

Rolf Hähle

**Mobile phones, Wi-Fi and satellite communications are increasingly making use of ever higher frequencies stretching up into the Gigahertz bands. That doesn't mean that there is nothing interesting going on at the other end of the radio spectrum. We build a simple receiver and tune into some of the more bizarre signals in the extremely low frequency (ELF) domain.**

A quick check on the tuner scale of any old analogue radio is all that is required to find out that the lowest frequency used for commercial broadcasting is 150 kHz on the long wave scale. That doesn't mean to say that if you were able to tune the radio below this frequency you would hear nothing but radio silence or maybe the odd crackle of static. Some of the bands below 150 kHz are used for scientific purposes and also for military applications. Communications with submerged submarines for example are carried out in the band between 70 and 80 Hz. As the transmission wavelength gets longer so the expenditure on transmitting and receiving equipment gets higher and higher. Submarine communication requires a kilometre long antenna and a very high power transmitter, however the advantage of this band is that the signal can penetrate almost everything and can be received anywhere, even under the sea. Some applications of the

low frequency bands are shown in the table.

In addition to these man-made signals there are some naturally occurring sources of radio signals below 150 kHz. The propagation of these signals is intimately related with the properties of the ionosphere and many radio amateurs have become experts in the study of these phenomena. Below 16 kHz in the VLF (Very Low Frequency) band it is possible to detect atmospherics or 'sferics'. These signals are produced where an electromagnetic pulse from a lightning stroke bounces around between the earth's surface and the ionosphere producing signals that can be categorised as 'tweaks' while others are 'whistlers' and another type is the 'dawn chorus'. The 'dawn chorus' occurs at daybreak and sounds like birds calling to one another. The electrical properties of the ionosphere are affected by radiation from the sun so signal paths are constantly changing.

Frequency bands					
	ELF	SLF	ULF	VLF	LF
	Extremely Low Frequency	Super Low Frequency	Ultra Low Frequency	Very Low Frequency	Low Frequency
<b>Frequency</b>	3 Hz to 30 Hz	30 Hz to 300 Hz	300 Hz to 3 kHz	3 kHz to 30 kHz	30 kHz to 300 kHz
<b>Applica-tion</b>	Technical maintenance: PIGs = Pipeline In-spection Gauges (20 Hz)  Military: Submarine communications  Signals of unknown origin	Military: Submarine communications: ZEVS Russia (82 Hz) Saguine USA (76 Hz)	Earthquake: Pre-quake sensing.  Communications below ground: Bunkers, caves	Worldwide broadcast for various applications (Between 10 and 30 kHz)  Omega navigation system: 10 to 14 kHz (up to 1997)  Sferics: Signals from natural events: 'Whistlers', 'Tweaks', 'Dawn Chorus'	Standard Time signals: DCF 77 Frankfurt (77.5 kHz) MSF Rugby UK (60 kHz) HBG Switzerland (75 kHz)  Military: Submarine communications (below 50 kHz)  Amateur radio: 137 kHz band in some countries

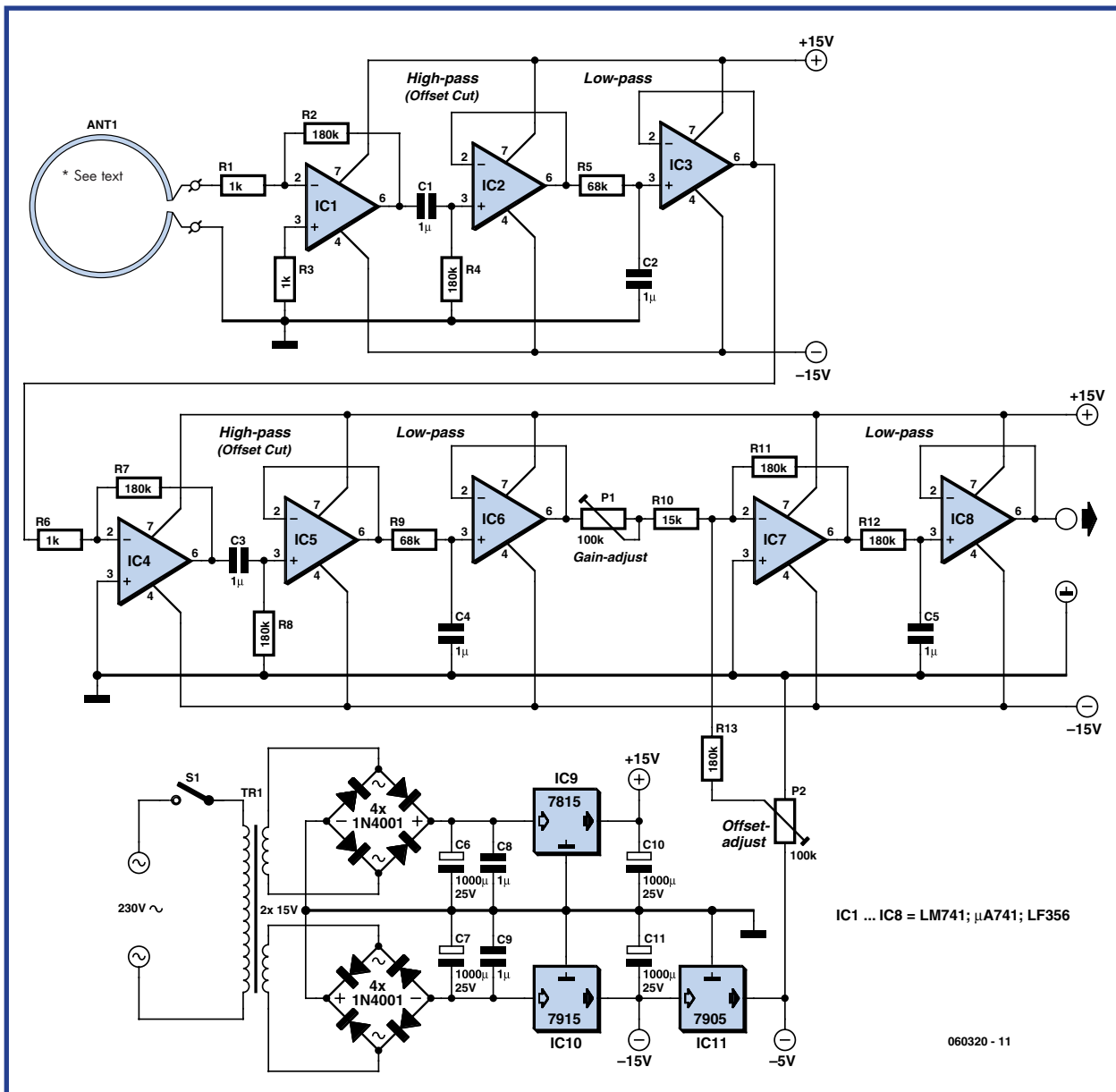

Figure 1. The ELF receiver circuit. The mains power supply can be replaced by batteries.

At these low frequencies there is no need to apply any demodulation to the signal, it is only necessary to convert the electromagnetic waves into audio waves. There are a number of Internet sites suggesting designs of receivers capable of picking up the types of signals mentioned above. Many of the designs stand little chance of picking up more than a mains hum signal if they are operated in a normal domestic environment. The 50 Hz or 60 Hz mains signal pervades most populated regions of the world and it is difficult to filter out even with a steep high-pass filter. The mains signal is ideally a pure sine wave but in practice it contains many higher order harmonics that extend into ultrasonic frequencies and these can block the signals of interest. VLF reception can only be successfully attempted once the receiver is situated far enough away from towns, villages, high voltage cables and factories. It goes without saying that a VLF receiver cannot be powered from the mains. Reception of ELF signals below 50 Hz does not present so many problems as the mains frequency (50 or 60 Hz) does not contain any lower order harmonics so it is relatively easy to remove its effect with a simple low-pass filter. A receiver for these ELF frequencies can be built

using just a highly sensitive audio amplifier together with a low-pass filter with a cut off frequency of around 20 Hz and a coil of wire to pick up the electromagnetic components of the signals (See the **inset** for details of coil construction).

### A low-pass filter does the trick

There are several different design suggestions for ELF receivers posted on the Internet but none of them are universally suitable for the application. One contributor suggests connecting a pick-up coil directly to the sound card input and relying on the software spectrum analyser program to recover the ELF signals. Interference from the mains frequency is however so much higher in the average environment that the really interesting ELF signals are completely swamped when this approach is used. Even with the addition of a low-pass filter the 50 Hz signal is still too large. In principle the signal induced in the coil need only be amplified by a factor of 100,000 (minimum) but it is important to ensure that the interfering 50 Hz signal is sufficiently suppressed before the signal is amplified too

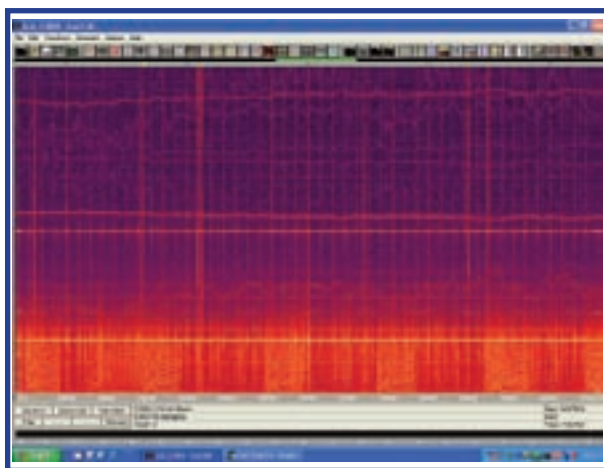

**Figure 2.** The receiver and power supply mounted in a small plastic housing. The connections go to the pick-up coil (in the black box) and to the laptop soundcard. The laptop is running CoolEdit.

much otherwise the amplifier will be driven into saturation by the mains signal. The receiver circuit suggested here amplifies the signal picked up by the coil before some of the 50 Hz content is removed by the first low-pass filter. The next stage provides the same amount of gain together with another low-pass filter. After the final filter the 50 Hz hum is barely perceptible on an oscilloscope display. The wanted ELF signals are however still present and can be further amplified or analysed.

### The Receiver Circuit

The circuit shown in **Figure 1** should be quite easy to follow for anyone with some experience in analogue design. Amplifier A1 is configured as an inverting amplifier and boosts the signal picked up in the coil by a factor of 180 and presents a low impedance match to the coil. This is followed by a high pass filter formed by C1 and R4 which has a corner frequency 1 Hz. This filter is not strictly necessary for the frequency response of the circuit but C1 ensures that the signal is AC coupled to the next stage so that any DC offset on the output of A1 is not amplified by successive stages. The high pass filters can be omitted if



**Figure 3.** Spectral content of the 'cow' signal. This is just one of over 20 different signals that the author has recorded.

more expensive offset-free op-amps are substituted here. A2 is simply a unity buffer amp while R5 and C2 form a low-pass filter, attenuating frequencies of 23 Hz and above. A3 is again a unity-gain buffer. The overall effect of these three opamps is to provide band pass filtering between 1 and 23 Hz together with some gain.

The following three amplifiers are a repeat of the first three and provide more gain and further attenuation of the 50 Hz signal. The unwanted mains hum signal becomes weaker after each stage while the signals of interest are amplified.

The resulting receiver is so sensitive that it can detect the movement of a small magnet (salvaged from an old loudspeaker) at a distance of 5 m. Waving the magnet up and down produces a corresponding sinewave on an oscilloscope connected to the amplifier output. The 50 Hz mains signal is barely perceptible on the oscilloscope trace.

### Not all plain sailing

The signals picked up by the circuit are of such low frequency that they are subsonic and by definition cannot be heard. There is also little point in displaying them on a standard oscilloscope because the signals are seen as a mixture of different frequencies and it is difficult to extract any meaningful information.

For this reason it is more useful to make a recording of the signals over a long period (15 minutes minimum) and then display them using a spectrum analyser. Both of these features are available in the audio editing program Cool Edit which is shown here in **Figure 2** running on a laptop PC.

This program is however designed to show the entire audio spectrum so the subsonic ELF signals are cramped up in the corner of the display which makes it difficult see what is going on at these frequencies.

The simplest way to expand the displayed ELF region is to fool the spectrum analyser into thinking that the received signal lies in the audio range (i.e. from around 50 Hz up to 20 kHz). This can be achieved by sampling the signal during recording at a one rate and then playing it back using a faster sample rate. It is basically the same technique as time lapse photography where slowly occurring events are played back much faster. For example a plant may take 100 days to develop from a seed to a flower. Growth is so slow that it is difficult to notice any difference from one day to the next but if you were to take a snapshot every four hours of the plant's life and then view the pictures at 25 frames per second the entire growth period would be shown in just 24 seconds. The same basic technique is used to capture, display and hear the ELF signals:

1. Connect the VLF receiver output to a PC sound card input and use a PC recorder program to store the received signal. Note that a standard PC sound card provides sharp attenuation to signals below 16 Hz.
2. The sample rate must not be higher than 200 Hz. If the recorder software does not allow selection of this low rate then it is necessary to write a program that effectively reduces the sampling down to this rate by just taking say every hundredth sample in the record file and discarding all the others in between. The effective sample rate is now one hundredth of the original.
3. The resultant sound file can now be used in the analyser program with the sampling rate set to 32 kHz which has the effect of multiplying the signal by 160 (assuming an original sample rate of 200 Hz) and making the signal

audible. The time lapse effect on the signals makes it possible immediately to see structures and patterns in some of these slowly changing received signals which are not obvious when the signals are observed in real time. The time and frequency markers displayed on the analyser program must of course be divided by the difference in sample rates to obtain their true values.

### Curious results

The strange nature of the signals that the author has picked up in this frequency band over the past six years really has justified the effort invested to build the ELF receiver. To start with the more banal signals that you are likely to tune into there is a weak 50 Hz line shown on the spectrogram produced by the ubiquitous mains power distribution network and also another signal peak at 16.66 Hz emanating from the railway network power distribution (in Germany) which can even be detected up to 6 km from the railway line! These two frequencies are not at all interesting but can be used as markers for testing the receiver. The majority of train networks outside the UK distribute power using overhead cabling; in Germany this generates a strong 16.66 Hz alternating electromagnetic field which swamps the input to the ELF receiver if it is operated within 1 km of the railway. These are probably the least interesting signals that you are likely to hear with this receiver. After many years of investigation into ELF phenomena the author has been able to identify locations on the earth's surface (in his locale) from where specific signals in the range from 0.8 to 20 Hz seem to emanate. The source of the signals is a mystery; some of the more interesting transmissions have particular characteristics and are strongest in certain areas.

Examples of processed ELF signals can be downloaded from our website at [www.ektor-electronics.co.uk](http://www.ektor-electronics.co.uk). The signal pitch of these sound files has been multiplied by 160 using the 'time lapse' technique described earlier to make them audible.

**Figure 3** shows the spectrum (against time) of a particular type of signal which has come to be known as the 'cow' signal. No prizes are on offer if you can guess what it sounds like once it has been transposed into an audible signal. In real time each transmission lasts for around five minutes and has been detected over a number of years, it occurs at random intervals, day or night and seems to be strongest along the main approach road around the northern edge of the village of Eifel in Germany.

The 'goose signal' sounds a bit like a quack when it is transposed but each sequence actually lasts for around one hour. There is a recognisable structure to the signal starting with what looks like a message 'header' and a (variable) series of mark/space pulses at about 16 Hz where each mark lasts for four periods. The complete sequence is repeated after 24 hours. Again this signal is quite localised to the Eifel region of Germany but has been detected up to 40 km away.

The 'heartbeat' signal sounds like the continuous emergency tone emitted by a heartbeat monitor. A look at the spectrum of this signal shows a fundamental frequency of less than 1 Hz with peaks at odd harmonics of the fundamental i.e. 3 and 5 times and so on. This characteristic indicates that the signal is actually a square wave. The signal begins at apparently random times and is interrupted at minute intervals; the entire broadcast can last for several hours and has been detected throughout

## The pick-up coil

The receiver antenna consists of a coil of about 1000 turns of fine enamel coated wire wound on a 40 cm diameter former. The wire can be salvaged from the primary windings of several old mains transformers (solder, then insulate the joints), alternatively a large spool of suitable wire can be purchased (the internet offers a good source of suppliers).



For coil winding a quick and simple former can be constructed by hammering in 8 nails evenly spaced around the circumference of a 40 cm circle drawn on a block of wood (don't hammer them in too far). A little patience and a notepad (you don't want to lose count half way through) is all that is necessary to wind the 1000 turns around the former. Insulating tape should now be wound around the finished winding to give some protection from the elements. The nails can now be carefully withdrawn to release the coil.

The finished coil is quite rigid and self-supporting but it helps to protect the fine wire from damage if it is fitted into a flat wooden box. A quarter inch mono jack socket can be fitted to the box to provide electrical connection to the coil.

NB: Ensure that the coil assembly is fixed firmly and not subject to vibration or any other type of movement during use, even a small movement interacts with the earth's magnetic field and induces a signal in the coil which can overload the input stage.

The coil can also be used for direction finding; the received signal will be strongest when the magnetic field lines are at 90° to the coil plane. The signals have a long period and the recording process is rather slow so it takes a great deal of patience to make the measurements necessary to identify the location of the signal source.

Germany. Listeners to this particular transmission have reported an increase in activity over the last three years. The signals are quite localised so it is unlikely that they have some connection with submarine communications or are of cosmic origin. One possible explanation is that they are generated by currents in the earth produced by the switching and operation of powerful electrical machines but if that were the case you would expect the signal structures to be similar each time they appeared and that is not the case. Maybe one day the mystery will be solved but until then it certainly makes interesting listening!

(060320-1)

### Web links

Example sound files at [www.ektor-electronics.co.uk](http://www.ektor-electronics.co.uk); click on Magazine → May 2007 → ELF Reception. [www.vlf.it](http://www.vlf.it)