

MK484 SHORTWAVE RADIO



TOM MERRYFIELD

Hit the shortwave trail with this two chip receiver

ALTHOUGH many a constructors have cut their teeth on building ZN414 radio circuits, the device, sadly no longer in production, now has a first class replacement in the MK484 a.m. radio chip.

The MK484 i.c. is a similarly three-pinned device with a.g.c. (automatic gain control) requiring only a few components to make a high quality tuner with a maximum supply voltage of just 1.8V. But that isn't all! The author was intrigued to see if it performed as well as its predecessor with the popular LM386 audio amplifier i.c. added to make a simple but effective shortwave radio project with loudspeaker output.

CIRCUIT DESCRIPTION

The results were quite surprising and the full circuit diagram for the MK484 Shortwave Radio is shown in Fig.1.

As with f.e.t.s, the circuit's high input impedance (several megohms!) is exploited to receive shortwave frequencies up to several megahertz (MHz), so long as the tuned circuit has negligible losses, thereby maintaining good selectivity.

The tuned circuit of the receiver is formed by L1, wound from 24 s.w.g. enamelled copper wire, and variable capacitor VC1. (For Cx and the aerial coil L2, see later.) Resistor R1 is needed to bias IC1, with capacitor C1 ensuring stability. As with other "front end" tuner components these should be soldered close to IC1, with coil L1 and VC1 leads to the circuit board kept as short as possible.

Resistor R3 and capacitor C2 play an important role in setting the optimum gain for the MK484. In theory, the gain could be increased until instability results but there would be a loss in audio quality – i.e.,

more noise – well before this point. Hence the selection of R3 and C2 values.

Given that the maximum allowable supply to the MK484 should not exceed 1.8V, in conjunction with resistor R4, diodes D1 and D2 stabilise the voltage at about 1.5V. Due to the voltage drop across resistor R3, this falls to between 1.3V and 1.4V; a typically safe working voltage for the radio chip.

Capacitor C3 is needed to block d.c. getting through to the following audio stage, whilst coupling IC1's output signal to the LM386 audio amplifier IC2, via Volume control VR1, at pin 3. Note also the bypass capacitor C4 preventing any stray r.f. from being connected to IC2.

From this point onwards the circuit is fairly typical with capacitor C5 setting the gain of IC2 and pins 2, 4 and 7 tied to ground, the latter via capacitor C6.

The inclusion of R6, C9, R5 and C7 prevents instability, thereby avoiding distortion in the output. In fact, the value of resistor R5 could be raised slightly higher to 18 ohms.

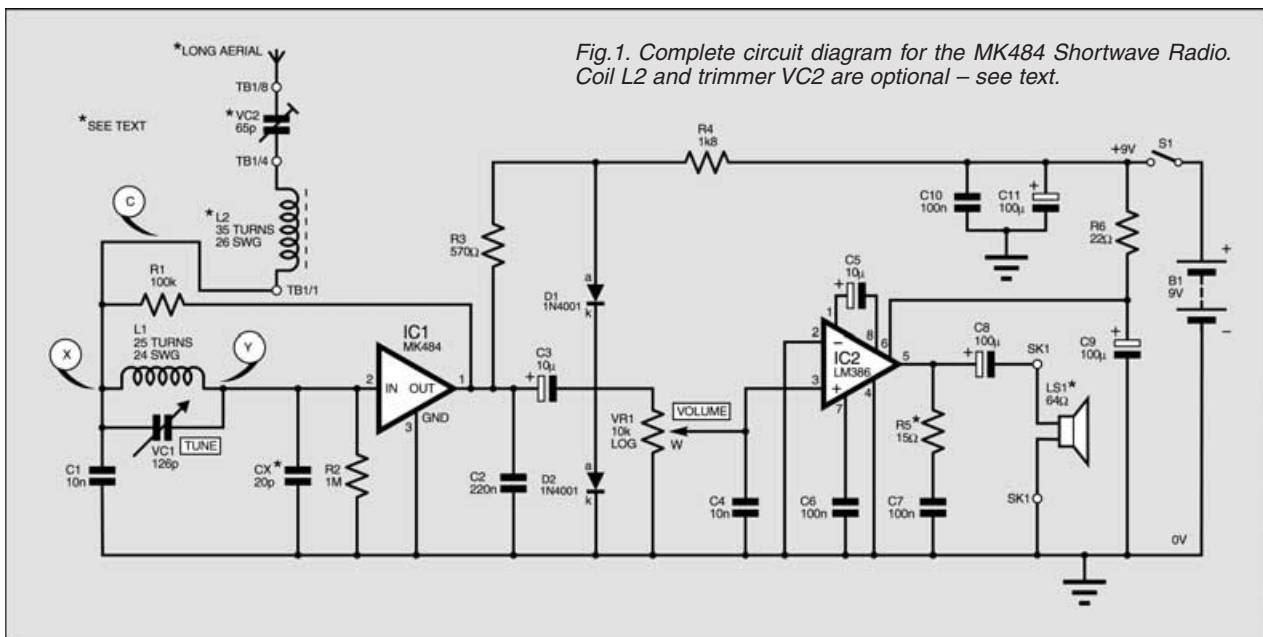

Fig.1. Complete circuit diagram for the MK484 Shortwave Radio. Coil L2 and trimmer VC2 are optional – see text.

With the output impedance being fairly low, a 64 ohm speaker gives a strong and even output but should be placed away from the tuned circuit area to avoid spurious feedback. For weaker signals however, Walkman type headphones can be used.

Q FACTOR AND AERIAL COIL

One point to bear in mind is that beyond 4MHz, losses in the tuned circuit heavily affect the selectivity. That is, the ability of a receiver to magnify a selected signal and reject others without an appreciable loss in gain.

In trials, the main coil L1 being loosely wound from 24 s.w.g. enamelled wire at 25 turns provided a suitable Q factor whilst still giving a broad enough tuning range.

As with most high gain devices at the front end, overloading tends to be a problem. This was certainly clear with the prototype. An ATU (Antenna Tuning Unit) would be ideal here in terms of matching the impedance of the aerial system and thus the signal to that of the receiver's input.

Failing that, an adequate measure is to connect up a long aerial lead via an aerial coil (L2) wound on a length of ferrite rod, and connected to the junction of R1, L1/VC1, via lead C (see Fig.1 and Fig.2.) This, in effect, provides additional tuning by sliding the aerial coil along the ferrite rod.

The long aerial itself can be any thin p.v.c. insulated connecting wire of 10 metres or so mounted as high as possible. For the most part this gives adequate results.

GETTING IN TRIM

In the prototype, a trimmer capacitor, VC2, was wired to the aerial circuit in series with the aerial coil L2 to give additional selectivity. With appropriate adjustment, this proved very effective in selecting individual signals from the crowded shortwave bands.

However, one precaution has to be observed; it is important to keep the aerial circuit and thus the aerial coil L2 well away from the main coil L1 and the receiver's input. Otherwise the signal can in effect bypass or "leapfrog" ahead instead of passing through the aerial coil!

Although the prototype was built on stripboard, a terminal block is ideal for wiring up the aerial coil L2 and trimmer capacitor VC2 and divorcing it from the tuned input circuit (Fig.2).

As a rough and ready filter, polystyrene capacitor Cx is needed to subdue stronger signals. Although a 20pF capacitor has been quoted, any value from 20pF to 50pF can be tried. In case a polystyrene isn't available, a ceramic-dipped or multi-layered capacitor also works well.

COIL WINDING

Some readers may be surprised at home-made coils being used in the receiver as opposed to commercial types. In trials, these proved far more effective than the latter whilst being simple to make and inexpensive.

Unfortunately, a badly constructed coil can impinge on the performance by inhibiting the Q factor. On the other hand this can be easily avoided, the key being a good former and plenty of patience.

The former on which coil turns are wound can be a sheet of thin cardboard or gum paper about 40mm by 35mm wide rolled into a tube. Its diameter should be slightly larger than that of any ferrite rod/slab used so it can freely slide up and down. It is, therefore, a good idea to make this check before proceeding further.

It is also important to apply sticky tape *inside* as well as out. This keeps the former robust enough to withstand compressive stresses.

As for winding the turns, any difficulties can be avoided by handling the wire tactfully so it doesn't tie itself up in knots. A good start is essential by securing the first few turns with insulation tape to prevent them from unwinding.

For the main coil L1, loosely wind 25 turns of 24 s.w.g. enamelled copper wire

onto the cardboard former, making sure there is a gap between most turns. Leaving short lengths at the start and finish of the coil for later attachment to the circuit board. Once completed, fasten the start and end windings with adhesive insulation tape and scrape the enamel coating off the end of the leads.

The aerial coil L2 should be made up of 35 turns of 26 s.w.g. enamelled wire more tightly wound with most turns touching. Once complete, check for any weak points and seal over with another application of tape or wax. The enamel coating for the "tailends" can be gently scraped off using sand-paper or emery cloth.

CONSTRUCTION

Despite employing quite a few capacitors, the receiver's simplicity means building it should not be too complicated a task.

COMPONENTS

Approx. Cost
Guidance Only

£18

excl. speaker & case

Resistors

R1	100k
R2	1M
R3	570Ω
R4	1k8
R5	15Ω
R6	22Ω

All 0.25W 5% carbon film

See
SHOP
TALK
page

Semiconductors

D1, D2	1N4001 1A 50V rect. diode (2 off)
IC1	MK484 a.m. radio i.c.
IC2	LM386 low voltage audio amp.

Miscellaneous

LS1	64 ohm 0.3W loudspeaker (see text)
SK1	3.5mm mono jack socket
S1	s.p.s.t. toggle switch
TB1	8-way screw terminal block
L1, L2	tuning coils (see text)

Stripboard, 0.1in. matrix, size 50 holes by 15 strips; plastic case, size approx. 160mm x 90mm x 55mm; 24 s.w.g. and 26 s.w.g. enamelled wire for coils; ferrite rod/slab; 8-pin d.i.l. socket; 9V battery, with PP3 type clips; long aerial wire (10m p.v.c. covered connecting wire); plastic knob, 16mm skirted; 12.5mm long hexagonal spacer; M2.5 x 15mm screw; M4 x 30mm stud with nut (2 off); adhesive strips and card for aerial formers; solder pins; solder etc.

Potentiometers

VR1	10k min. rotary carbon, log.
-----	------------------------------

Capacitors

C1, C4	10n mylar poly. (2 off)
C2	220n mylar polyester
C3, C5	10μ radial elect. 25V (2 off)
C6, C7	100n disc ceramic, 5mm pitch (2 off)
C8, C11	100μ radial elect. 25V (2 off)
C9	100μ axial elect. 25V
C10	100n mylar polyester
Cx	20p axial polystyrene (see text)
VC1	126p min. a.m./f.m. tuning capacitor (ZN414 type)
VC2	5.5p to 65p min. trimmer



The prototype was built on a piece of stripboard measuring 50 holes by 15 copper tracks.

The topside component layout, interwiring and details of the breaks required in the underside copper tracks are shown in Fig.2. Commence construction by making all the necessary copper track breaks and inserting all the link wires (9 off).

This should be followed by inserting the resistors, capacitors, diodes and the two i.c.s. Care should, of course, be taken to ensure that diodes and electrolytic capacitors are inserted the correct way round. Wiring-up the aerial coils, volume control and tuning capacitor is carried out later when assembling the circuit board into a case.

Because the MK484 i.c. can be damaged by excessive heat, some form of heatsink is necessary during soldering. For instance, holding the device with metal tweezers to conduct the heat away whilst soldering it in; or attaching a croc-clip. An i.c. holder should be used for the LM386, IC2.

Once the soldering is complete, check for dry joints and tiny splashes of solder between tracks – the latter can be very easily missed, contributing to the “invisible short circuit” phenomenon. Also, double-check that all polarised components are correctly wired on the circuit board.

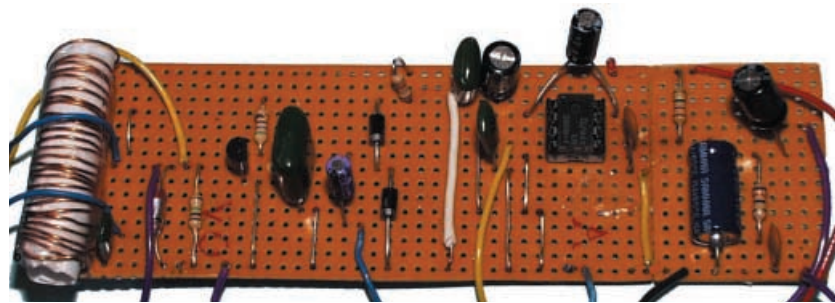

Prototype stripboard component layout.

As stated previously, the aerial coil L2 and trimmer capacitor VC2 should not be soldered directly to the board, but instead are wired via an 8-way terminal block. To help reduce losses at higher frequencies, keep the tuned circuit leads as short as possible.

TESTING

Although designed for shortwave use, the receiver can be easily tested in medium wave mode to see if everything works.

A pre-wound MW coil or one made from 30s.w.g. wire of 50 to 60 turns on a ferrite rod acts as the main coil for receiving MW frequencies. Also, no aerial, aerial coil or trimmer is required. If all is well, a strong and

even output should be heard from the speaker or headphones at a half turn of the Volume control VR1.

CASING IT UP

Bearing in mind the prototype was used for the reception of high frequency bands with Walkman type headphones, the unit was cased in a box approximately 160mm x 95mm x 55mm high, without the speaker.

This kept things simple by using a 3.5mm mono socket for either headphone or a loudspeaker output. If preferred, a speaker could be mounted in a bigger case with a series of perforations over the speaker section.

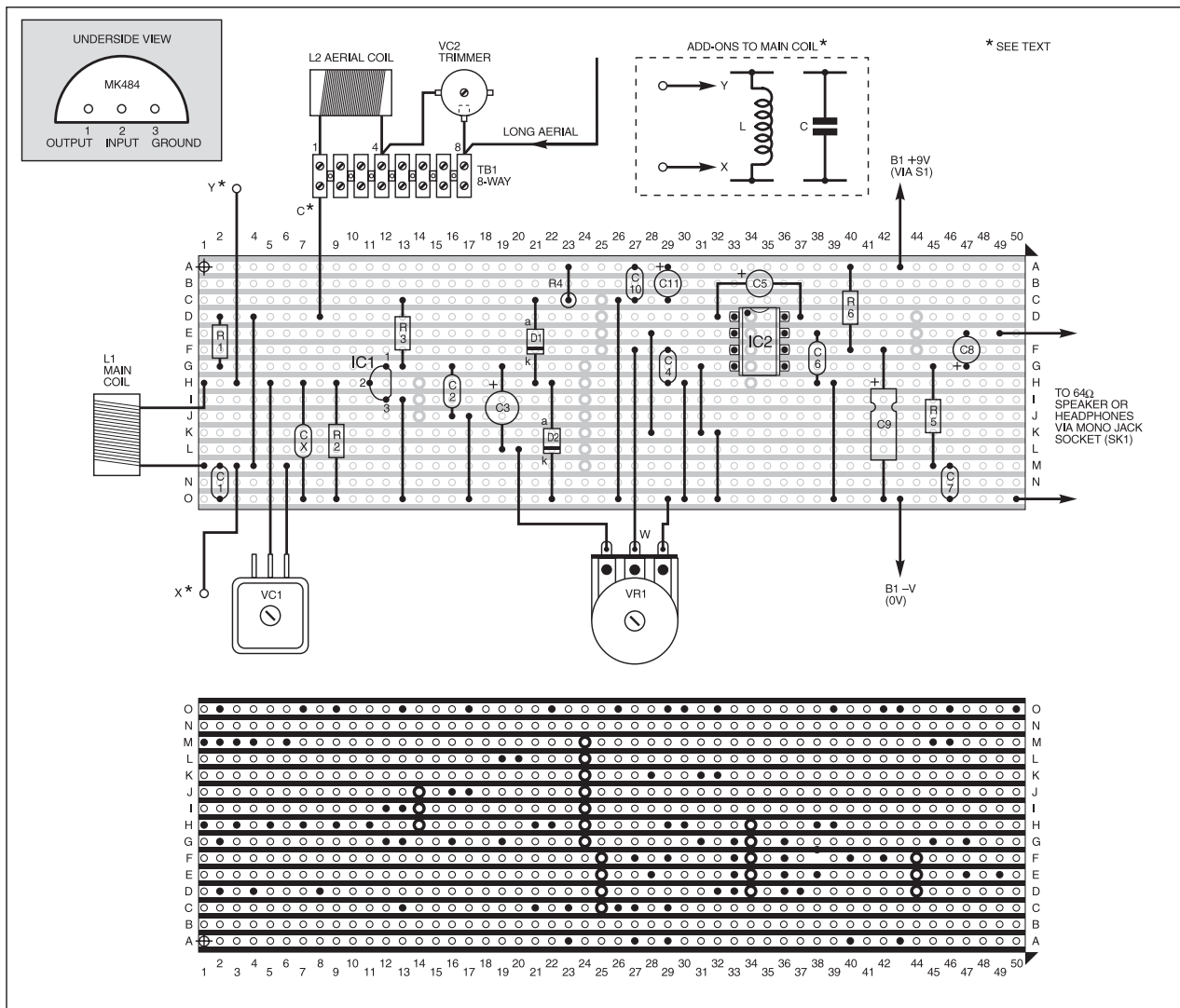

Fig.2. Stripboard component layout, interwiring and details of breaks required in the underside copper tracks. Pinout details (underside) for the MK484 radio chip are shown inset top left. Leads X and Y are for attaching additional tuning components.

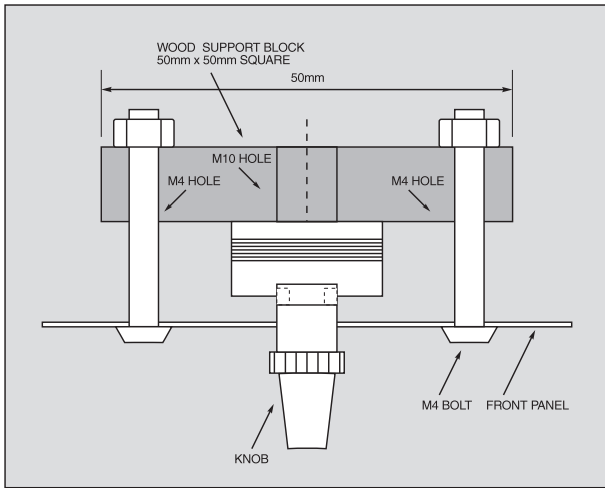

Fig. 3. Suggested method of fitting the variable tuning capacitor VC1 to the front panel.

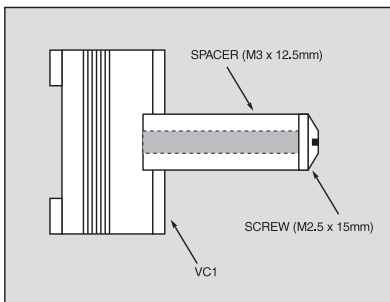
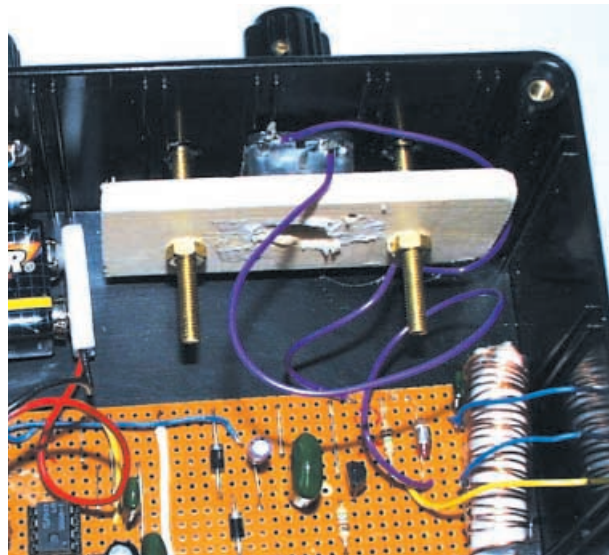

Fig. 4. Lengthening the tuning capacitor spindle.

In terms of varying the frequency range, this can be achieved by adding a second coil or low value polystyrene capacitor in parallel with the main coil. Hence the leads X and Y in Fig. 2. Given that the main coil L1 is soldered in-circuit, the "additions" can be wired up using a terminal block; as

with the aerial circuit this is placed outside of the case. The circuit board and battery were simply affixed to the bottom panel of the case using adhesive pads.

TUNING CAPACITOR

More challenging is mounting the standard a.m. variable capacitor (VC1) securely to the panel. Basically, this isn't easy because of the tuner's dimensions, so a bit of improvising is needed.

As Fig. 3 shows, a square offcut of thin wood or plastic measuring around 50mm x 50mm acts as a support to keep VC1 in place relative to the panel via M4 studs after drilling holes.

The problem of lengthening VC1's shaft is solved by using a hexagon spacer secured with an M2.5 screw of appropriate length, see Fig. 4. Care is needed here not to drive the screw too far into the capacitor, this risks damaging the vanes. A knob can then be attached,

preferably with an adjustable grub screw fixing.

RESULTS

The prototype picked up many stations from all over Europe including Sweden and Denmark and several American religious broadcasts on the 41 metre band. The latter signals, however, required fine-tuning via the trimmer using a small screwdriver.

For higher frequencies, including the 25 metre band, little or no adjustment of the aerial coil may be needed. This includes broadcasts from China and many arabic stations including the United Arab Emirates.

Depending on atmospheric conditions and propagational effects, some fading of the signal is likely to occur at these frequencies. Of course, this happens with more complex receivers but to a lesser degree due to better signal processing and more stages.

That being said, Radio Korea, Turkey and Egypt were received loud and clear. Generally, the best time to try the h.f. bands is during the evenings when propagation conditions are better.

For those who would like to experiment, using different coils or varying the turns of the main coil always brings interesting results.

With practised intuition, plenty of signals can be tuned in, making the MK484 radio chip an impressive replacement for the ZN414. □



The completed prototype MK484 Shortwave Radio.

