

VocalMaster—A Speech Processor for Low Power Operators

Build this versatile and attractive accessory for the Yaesu FT-817 to give you more talk power.

Allen Baker, KG4JJH

I have had a lot of fun operating low power with my Yaesu FT-817 portable HF transceiver, but have often wished that it had some audio or RF processing to add a little SSB punch. There are some excellent audio processing accessories available commercially, but I thought this would make a great homebrew project reminiscent of the early Heathkit days. With this in mind, I began to look for suitable building blocks to bring this idea to life.

Design Goals

I wanted to incorporate several design goals. First, the enclosure should be smaller than my radio, aesthetically pleasing, and made of steel or aluminum to provide RF shielding. Second, all of the components should mount on a printed circuit board with no point-to-point wiring to jacks or controls. Third, the input and output jacks must match the rig's microphone connector. Fourth, I wanted some visual feedback on what was going on inside the box, such as an output level meter. And fifth, a built-in signal generator for antenna tuning would be an added bonus. The end result would combine all of these features into a small package that includes RF filtering and front panel controls, and is powered from the rig's mic voltage.

One of the first challenges was finding a compressor IC that would operate on the 5 V dc available at my radio's mic jack. Several ICs are available that are used in professional audio equipment but they require ± 12 V dc. The Analog Devices SSM2165/2166 series of ICs will operate on 5 V dc and I found several articles on their implementation.¹ Unfortunately, the manufacturer has discontinued the dual in-line package (DIP) version of this device. They now only offer the chips as tiny surface mounted devices (SMD) that are much harder to install. After much con-



sternation, I decided to prototype the circuit using a solderless breadboard and then lay out a printed circuit board.

Circuit Description

The fact that the SSM2166 combines a mic preamplifier, noise gate, compressor and limiter into one IC explains its popularity. A low-noise voltage controlled amplifier (VCA) provides gain that is adjusted by a control loop to provide compression. The

compression ratio can be varied from 1:1 to 15:1 relative to a rotation point. Signals above this rotation point, or limiting threshold, can then be limited to eliminate overload. A noise gate with adjustable time release prevents amplification of noise or hum. The unit performs all of this while boasting low noise and distortion over a 20 kHz bandwidth. The resulting microphone audio signal is thus optimized for communication use. Figure 1 shows the input-output response at different

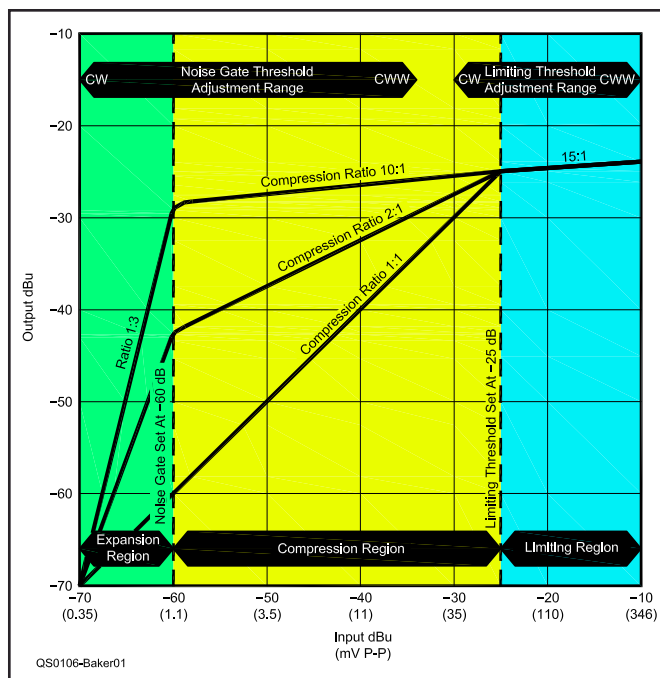
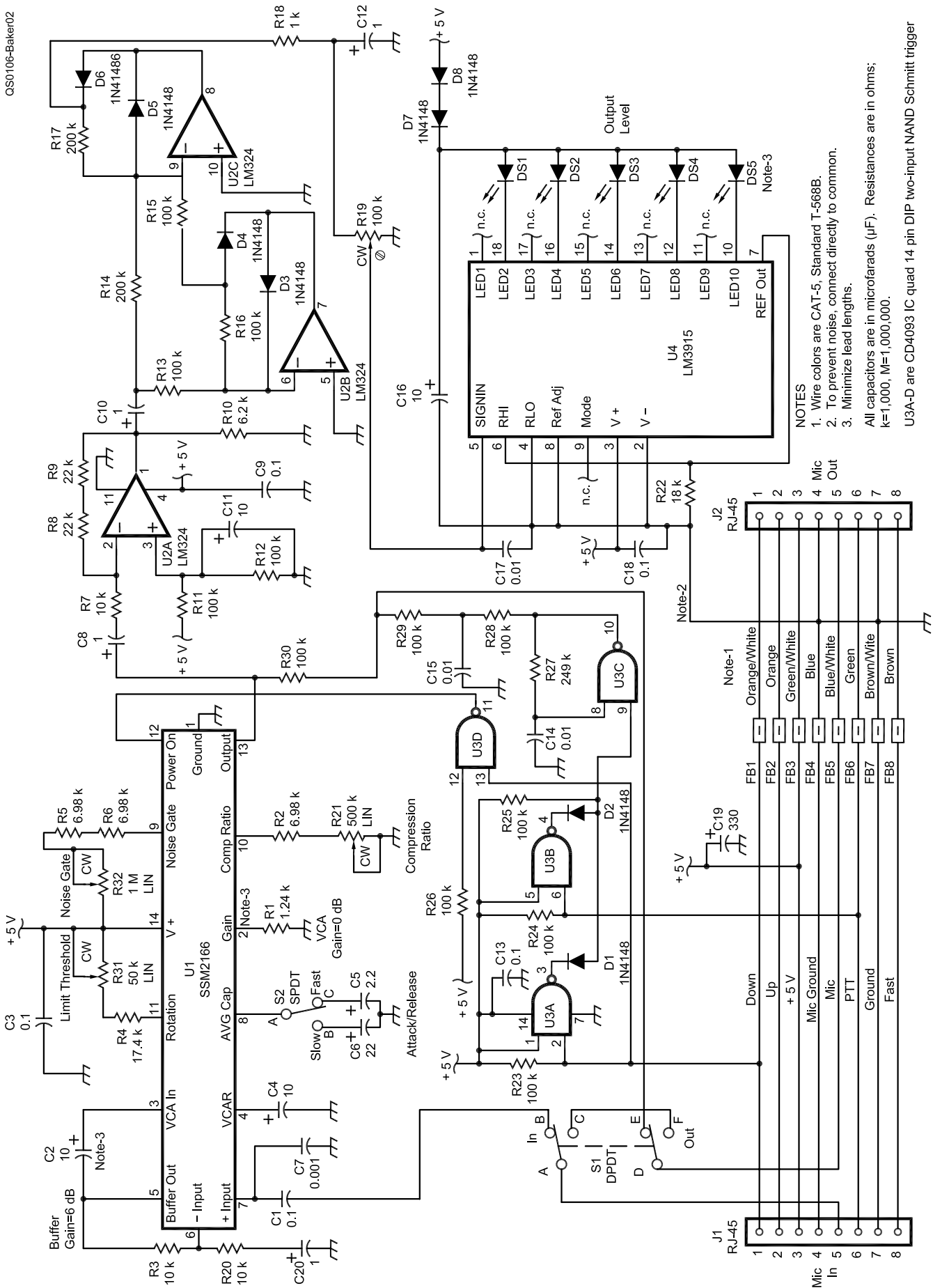

Figure 1—Compressor input-output response at different compression settings.

¹Notes appear on page 35.



NOTES
 1. Wire colors are CAT-5, Standard T-568B.
 2. To prevent noise, connect directly to common.
 3. Minimize lead lengths.
 All capacitors are in microfarads (µF). Resistances are in ohms; k=1,000, M=1,000,000.

U3A-D are CD4093 IC quad 14 pin DIP two-input NAND Schmitt trigger

Figure 2—Detailed schematic diagram and parts list for the VocalMaster. Resistors are ¼ W, 1%. Most components are stocked by major distributors such as DigiKey (www.digikey.com), Mouser (www.mouser.com) and Ocean State Electronics (www.oselectronics.com). Some special parts are available from Palomar (www.palomar-engineers.com), ExpressPCB (www.expresspcb.com), Small Bear Electronics (www.smallbearslec.com) and McMaster-Carr (www.mcmaster-carr.com).

- C1—0.1 µF, 100 V polyester capacitor.
 C2, C4, C11, C16—10 µF, 16 V electrolytic capacitor.
 C3, C9, C13, C18—0.1 µF, 50 V ceramic capacitor.
 C5—2.2 µF, 16 V electrolytic capacitor.
 C6—22 µF, 16 V electrolytic capacitor.
 C7—0.001 µF, 50 V ceramic capacitor.
 C8, C10, C12, C20—1.0 µF, 16 V electrolytic capacitor.
 C14—0.01 µF, 100 V polystyrene capacitor, 5%.
 C15, C17—0.01 µF, 50 V ceramic capacitor.
 C19—330 µF, 16 V electrolytic capacitor.
 D1-D6—1N4148 diode.
 D7, D8—1N4001 diode.
 DS1-DS3—2 mA green LED (Mouser 645-551-1307).
 DS4—2 mA yellow LED (Mouser 645-551-1207).
 DS5—2 mA red LED (Mouser 645-551-1107).
 FB1-FB8—Ferrite bead (Palomar FB-1, Mix 43).
 J1-J2—RJ-45 connector (Mouser 154-UL6883).
 R1—1.24 kΩ metal film resistor.
 R2, R5, R6—6.98 kΩ metal film resistor.
 R3, R7, R20—10 kΩ metal film resistor.
 R4—17.4 kΩ metal film resistor.
 R8, R9—22 kΩ metal film resistor.
 R10—6.2 kΩ metal film resistor.
 R11-R13, R15, R16, R23-26, R28-R30—100 kΩ metal film resistor.
 R14, R17—200 kΩ metal film resistor.
 R18—1 kΩ metal film resistor.
 R19—100 kΩ single turn trimpot (Mouser 652-3386P-1-103T).
 R21—500 kΩ, 9 mm potentiometer, linear taper (Mouser 317-2081-500K).
 R22—18 kΩ metal film resistor.
 R27—249 kΩ metal film resistor.
 R31—50 kΩ, 9 mm potentiometer, linear taper (Mouser 317-2081-50K).
 R32—1 MΩ, 9 mm potentiometer, linear taper (Mouser 317-2081-1M).
 S1—DPDT toggle switch (Mouser 10TF160).
 S2—SPDT toggle switch (Mouser 10TF130).
 U1—SSM2166P 14 pin DIP mic preamp IC (Small Bear Electronics SSM2166P).
 U1 (Alternate)—SSM2166S 14 pin SMD mic preamp IC (DigiKey SSM2166S-ND).
 U2—LM324 single supply 14 pin DIP op amp IC (Mouser 595-LM324AN).
 U3—CD4093 quad 14 pin DIP two-input NAND Schmitt trigger IC (Mouser 595-CD4093BE).
 U4—LM3915 18 pin DIP LED dot/bar driver IC (DigiKey LM3915N-1-ND).
 PCB—Two sided printed circuit board (Express PCB).
 Aluminum enclosure, 4.7×4.1×1.2 inches (Mouser 546-1455L1201BK).
 RJ-45 Patch Cable, 2 feet long.
 Brass hex spacer, 4-40 × ¼ inch (Mouser 534-1450A).
 Pan head machine screw with internal washer, 4-40 × ⅜ inch (McMaster-Carr #90403A104).
 DIP IC socket, 14 pin (Mouser 517-ICE-143-S-TG30).
 DIP IC Socket, 18 pin (Mouser 517-ICE-183-S-TG30).



Figure 3—Inside top view of the completed VocalMaster.

compression settings. Figure 2 provides the schematic and parts list.

Controls

All user controls are accessible from the front panel. While they may end up being *set-and-forget* controls after they have been properly adjusted, I prefer to have them within easy reach for tweaking. The potentiometers were selected to fit in the small enclosure and do not require knobs. BYPASS switch S1 toggles the processing IN and OUT to let you get signal report feedback and for FM use. Switch S2 establishes the level detector averaging time constant. With S2 in the FAST position, the attack time is 22 ms and the release time is 240 dB/s. With S2 the SLOW position the attack time is 220 ms and the release time is 12 dB/second.

Processor Controls

The processor, U1, an SSM2166,² has its input buffer gain initially set to 6 dB and the VCA gain is set to 0 dB. The NOISE GATE control sets the noise gate threshold. Turning clockwise reduces the threshold and sets the level below which input signals are downward expanded at a ratio of 1:3. The COMP RATIO control establishes the compression ratio over the range of 1:1 to 15:1. Turning clockwise increases the ratio. The LIMITING THRESHOLD control determines the level at which limiting begins. Turning clockwise reduces the level at which limiting occurs.

Output Level Meter

The output of U1 (pin 13) is fed to U2, an LM324.³ Amplifiers U2A, U2B and U2C form a precision full-wave peak detector that drives the input of U4, an LM3915.⁴ U4 is

set for dot mode and drives low current LEDs to minimize the current demand. Illumination of the green LEDs with an occasional yellow LED indicates output levels in a “safe” area of operation. The red LED indicates a distorted signal and should rarely illuminate if everything is adjusted properly. Trimpot R19 allows the meter to be adjustable.

Mic Input and Output

The RJ-45 microphone input jack at J1 matches the FT-817 microphone. The microphone output at J2 uses a similar connector and is connected to the FT-817 microphone input via a standard CAT-5 computer network patch cord. The microphone and patch cables are not shielded. Instead, they rely on the fact that twisted-pair wires inherently reject noise. All eight microphone wires employ ferrite beads to attenuate any RF. If your VocalMaster is for a radio with different mic connectors, make the appropriate substitution of connector types to fit your radio and microphone.

Signal Generator

A novel circuit⁵ for providing an 800 Hz tuning signal is provided by U3, a CD4093. U3C forms an astable oscillator with the frequency determined by $2/(R27 \times C14)$. A square wave will be produced at pin 10 whenever pins 2 and 6 are pulled low. R28 and C15 form a simple 160 Hz low-pass filter that modifies the output into a triangular wave. U3D powers down U1 when the signal generator is active and mutes the microphone. To activate the generator, press and hold the microphone push-to-talk (PTT) button and then press the DOWN button. The

Table 1
FT-817 Adjustment Settings

Control	Function	Initial Position	Full CCW 0	Midpoint 5	Full CW 10	KG4JJH settings
R32	Noise Gate Threshold	10	15 mV _{rms} (-34 dBu ¹⁰)	0.55 mV _{rms} (-63 dBu)	100 μV _{rms} (-78 dBu)	10 (-63 dBu)
R21	Compression Ratio	0	1:1	10:1	15:1	5
R31	Limiting Threshold	0	0.1 V _{rms} (-18 dBu)	0.040 V _{rms} (-26 dBu)	0.025 V _{rms} (-30 dBu)	5 (-26 dBu)
S1	Bypass	IN				IN
S2	Attack Release	SLOW				SLOW

functionality of the microphone UP, DOWN, and FAST buttons are not affected.

Power Requirements

The current requirements (measured values) for this circuit are 13.9 mA during normal operation and 4.4 mA when the signal generator is on. The FT-817 mic power lead was found to deliver up to approximately 15 mA before the voltage dropped below 4.85 V dc, indicating that it should power the VocalMaster without any problems. For other radios, the mic supply voltage may or may not be up to the task. If not, a different source of 5 V must be found from within or outside the radio.

Printed Circuit Board

I was fortunate to have an SSM2166S on hand, courtesy of Analog Devices, and this prompted me to start the prototype. I made an SMD to DIP adapter to allow me to use a solderless breadboard designed for DIP devices. After I had completed the PCB layout I discovered a source for the DIP package, the SSM2166P,⁶ for which I completed a second version. Both versions of the PCB employ the manufacturer's advice on star grounding and short lead lengths to minimize instability. Builders should get the desired chip *before* ordering one of the two versions of the PCB.

I ordered prototype printed circuit boards from ExpressPCB.⁷ I chose the most economical approach by ordering boards that are double sided with plated through holes but do not have a solder mask or component silk screening. Regardless of the manufacturer, groups of builders or clubs should get together and order the boards in quantities to reduce the cost. You can see the various cost breakdowns by installing the free PCB software and loading one of the layouts, *VocalMaster-DIP.pcb* or *VocalMaster-SMD.pcb*. If the PCB does not have plated-through holes, be sure to solder the components on both sides of the board. Additionally, if the pad is a feedthrough, insert a short length of wire and solder on both sides. The inside top view of the completed VocalMaster is shown in Figure 3. Check with the author to deter-

mine the availability of fabricated boards.

Printed Circuit Assembly

Install the components by referring to the printed circuit board (PCB) assembly drawing for part numbers and locations, and the materials list for corresponding values. For the DIP version, use a small soldering iron of 25 W or less with a standard small tip. For the SMD version, a very tiny tipped iron (¹/₁₆ inch) and a magnifier are mandatory for soldering the SSM2166P.

A beginners guide to surface mount technology is a good starting point to get you acquainted with the tools and methods involved.⁸ Work with plenty of light and use small gauge solder sparingly, as the PCB pads are small. Too much solder will increase the chance of a solder bridge, especially on boards without a solder mask. Cleaning the tip on a damp sponge before every solder joint will decrease the chances of a faulty connection. Although not mandatory, I encourage the use of IC sockets to aid in testing and troubleshooting. Observe polarity on all ICs, diodes and electrolytic capacitors. All components should be mounted close to the board to minimize lead lengths.

Trimpot R19 will be adjusted following assembly to illuminate the red LED on audio peaks that produce distortion in the transmitted signal.

Save the clipped ends of component wires for installing ferrite beads FB1-FB8. Install all components except U1, U2, U3 and U4. Take your time and check your work. If your eyes are as bad as mine, a magnifying glass, headband or worklight may come in handy. When you are satisfied, connect MIC OUT to the radio microphone input with a short jumper cable. Attach the negative lead of a dc voltmeter to the PCB common connection. Turn on the radio, and, using the voltmeter positive lead, check for 5 ±0.2 V dc at the following locations: U1, pin 14; U2, pin 4; U3, pin 14, and U4, pin 3. If all voltages are okay, remove power and connect the mic to the MIC IN jack, J1. Place S1 in the OUT position and ensure that the radio is functioning normally, including the microphone

audio, UP, DOWN and FAST functions. If you experience problems go back and inspect the PCB for incorrectly installed components, reversed polarities, solder bridges, and faulty solder joints. When the test is successful, remove power and install the ICs in their sockets. Pin 1 is identified with a square pad on the PCB. Make sure all pins are aligned before pressing them into the sockets or you may bend them.

Enclosure

Using rubber cement, secure the templates (see drawing sheet 3, www.arrl.org/files/qst-binaries/Baker0106.zip) and drill all holes on the front and rear panels. The rectangular holes on the rear panel will also require a file and some elbow grease to get them properly sized. To improve the appearance of the front panel holes, use a countersinking bit to lightly remove the rough edges. You may want to blacken the hole edges using an aluminum blacking solution, sold in gun stores. I used white enamel paint on the control indicator marks to make them more visible. Using a small jeweler's screwdriver, dip the tip into the paint and touch the inside of the control slots. Use small amounts and allow the paint to flow only into the slot. Clean up using a cotton swab damped with paint thinner.

Labeling was added using white dry transfer letters. Print a full size template onto clear film. Tape the panel to a flat surface and clean it with rubbing alcohol. Tape the top edge of the clear template over the panel. Insert the dry transfer sheet in between, line up each character under the template and burnish. I used ¹/₈, ³/₃₂ and ¹/₁₆ inch characters found in the HO railroad section of my local hobby shop.⁹ Clean up with masking tape and cotton swabs moistened with alcohol. Seal the lettering by spraying on two light coats of clear lacquer or decal sealer. Figure 4 shows the details of the front panel lettering.

It is important to note that the removable panel is located at the enclosure top. This is to allow access to R19 and to prevent the PCB traces from contacting the enclosure PCB mounting channels. Attach the front bezel



Figure 4—Details of the front panel lettering.

and panel and slide the PCB into the bottom rails of the enclosure from the rear until the front of the PCB touches the inside of the front panel. Mark the mounting hole location on the bottom of the enclosure and drill a $\frac{1}{2}$ inch diameter hole. Scrape away any paint or anodizing around the inside of this hole to ensure a good electrical connection between the enclosure and the PCB. Attach the spacer on the bottom center of the completed PCB with a $4-40 \times \frac{3}{16}$ inch screw with internal lockwasher and slide it into the enclosure. Guide the controls through the front panel cutouts and insert the panel screws. Be very careful not to over tighten the front and rear panel screws as the aluminum holes are easily stripped. After adjusting R19 in the next section, slide in the top panel, rear bezel, and rear panel and install the four rubber feet on the bottom. Complete the assembly by securing the PCB mounted spacer with a $4-40 \times \frac{3}{16}$ inch screw with internal lockwasher from the enclosure bottom.

Setup and Operation

The following instructions are FT-817 specific. For other radios, check the manual for the appropriate control function. FT-817 menu 46 (SSB MIC) should initially be set to the default value of 50. Plug one end of a standard 1 to 3 foot CAT-5 patch cable into MIC OUT jack J2 and the other end into the FT-817 microphone jack. Plug the MH-31 microphone into MIC IN jack J1. (Please note that the VocalMaster is designed to work only with the standard MH-31 microphone. The optional DTMF microphone is not compatible.) Connect a dummy load to the radio, and monitor the transmitted signal on a second rig using headphones. It is very important to monitor your transmitted audio until you have adjusted R19 and are familiar with the operation of the VocalMaster, as improper settings may produce a noisy or distorted signal.

While monitoring your transmitted signal, adjust the controls as follows: TIME CONSTANT to SLOW, NOISE GATE to 10, COMP RATIO to 10, and LIMIT THRESHOLD to 0. At these settings you should hear distortion in the transmitted signal. Adjust R19 to illuminate the red LED on these audio peaks.

0. Speak into the microphone with the processor IN and note that two or three green LEDs illuminate. Continue speaking and slowly turn COMP RATIO clockwise until the red LED turns on. A high compression ratio coupled with a low limiting threshold will yield a high output level, which could overload the radio's audio input. These settings will also raise the background noise level and could introduce audible distortion and "breathing or pumping" effects. Reduce the output level by lowering the compression ratio and/or lowering the limiting threshold. Turn LIMIT THRESHOLD clockwise and notice that the output level diminishes. With the compression ratio set to 2:1, a 6 dB change of the input signal level in the compression region causes a 3 dB change in the output level. Likewise, at 10:1 compression, a 10 dB change of the input signal level in the compression region causes a 1 dB change in the output level. Holding the microphone closer to your mouth reduces ambient room noise and gives the audio more presence. If you speak softly or hold the microphone farther away, access FT-817 Menu 46 for further SSB microphone gain adjustments.

The controls are somewhat interactive so experiment with the settings to hear how they affect the audio. Table-1 lists initial positions, general parameters at various settings, and the optimum settings for my operating conditions.

The compression ratio will keep the output steady over a wide range of microphone to speaker distance, and the noise gate will reduce background noises. Signals above the limiting threshold are limited at a compression ratio of 15:1 to eliminate overloads. A graph of the Input/Output Characteristics is shown in Figure 1, and two audio WAV files (*VocalMaster-Quiet.wav* and *VocalMaster-Noisy.wav*) are posted on the ARRL Web site (www.arrl.org/files/qst-binaries/Baker0106.zip) to let you hear the sound of a VocalMastered SSB signal in a quiet and noisy environment.

Conclusion

I am delighted to report that all of the design goals have been met. The aluminum enclosure is smaller than my FT-817¹¹ and

The LED output level meter is always active when the bypass switch is in the IN position. This feature allows you to adjust the controls without transmitting (ie, PTT is off). Initially, set the time constant to SLOW, NOISE GATE to 10, COMP RATIO to 1, and LIMIT THRESHOLD to

provides good shielding. All components mount on a printed circuit board, including the microphone connectors. An LED output level meter provides visual feedback, and a built-in signal generator simplifies antenna tuning. As an added bonus, the Yaesu FT-857 and FT-897 also use the MH-31 microphone, so the processor can be used on all three rigs. On-the-air reports with the FT-817 have been very favorable with an average 6 dB increase in signal strength. The VocalMaster will enhance your SSB signal and you will be proud to place this eye-catching accessory next to your rig. Once you have rounded up all of the parts this project can be completed in a weekend, so heat up your soldering iron and give your QRP station some pizzazz!

Notes

¹M. Gonsior, W6FR, "MikeMaster—A Microphone Preamplifier with Noise Gating and Compression, *QST*, Mar 1998, pp 33-36; P. Salas, AD5X, "FT-817 Speech Compressor," www.aham.net/articles/2627; J. Orman, "Q&D Compressor 2," www.muzique.com/ssm2166.htm.

²Analog Devices, "Microphone Preamplifier with Noise Gating and Compression, SSM-2166 DataSheet," www.analog.com/UploadedFiles/Data_Sheets/83095497SSM2166_b_.pdf.

³LM123 LM224 LM324 LM2902 Low Power Quad Operational Amplifiers, National Semiconductor, www.national.com/ds/LM/LM124.pdf.

⁴LM3915 Dot Bar Display Driver, National Semiconductor, www.national.com/ds/LM/LM3915.pdf.

⁵K. Theurich, DG0ZB, "Dynamic Compressor for the FT-817," *FunkAmateur*, Apr 2002, p 389.

⁶Steve Daniels of Small Bear Electronics has indicated that he has 200 of the SSM2166P chips with more available on the wholesale market; www.smallbearelec.com/Ordering/ICsCompExp.htm.

⁷ExpressPCB, printed circuit boards and free software, www.expresspcb.com. Contact the author to determine the availability of pre-fabricated PC boards.

⁸S Ulbing, N4UAU, "Surface Mount Technology—You Can Work With It!," *QST*; Part 1, Apr 1999, pp 33-39; Part 2, May 1999, pp 48-50; Part 3, Jun 1999, pp 34-36; Part 4, Jul 1999, pp 38-41.

⁹Dry Transfer Decals, Woodland Scenes, #WOODT507.

¹⁰dBu is a means of expressing voltage, referenced to 0.775 V, regardless of impedance. One mW of power is dissipated if 0.775 V is applied to a 600 Ω load, so for a load impedance of 600 Ω , 0 dBu = 0 dBm.

¹¹The VocalMaster was designed with the FT-817 in mind, but should work with any transceiver that uses a 600 Ω mic at the appropriate level and has 5 V available.

Allen Baker, KG4JJH, received his license in 2000, after a lifelong dream of becoming a ham. He holds a BS in Industrial Engineering from Tennessee Technological University and works as an Instrumentation & Controls Engineer for the company that operates the US Department of Energy weapons plant in Oak Ridge, Tennessee. Allen is active on SSB and the digital modes, enjoys the challenge of working QRP and loves to experiment with antennas and radio gear. He can be reached at 211 Brochardt Blvd, Knoxville, TN 37934 or kg4jjh@arrl.net. 